



---

1001 Main Street Fortuna, CA 95540-2008 (707) 725-9000

---

Website: ccrane.com Email: ccraneco@aol.com

---

## **SELECT-A-TENNA DIRECTIONS**

(Also helpful for the Terk AM Advantage)

The SELECT-A-TENNA is a highly sensitive AM radio antenna that requires no connection to your radio. It uses no batteries nor external power source of any kind. Used with your radio it creates a super-sensitive radio-antenna combination better than the most expensive radio on the retail market.



Long distance nighttime reception depends on the skywave signal. The skywave generally fades in signal strength causing periodic interruptions in service. The SELECT-A-TENNA boosts the weak signal and in most cases almost completely eliminates signal dropout. For daytime listening, the SELECT-A-TENNA effectively doubles the normal listening range of a radio station anywhere in the country. Our experience has shown that at distances of 700 miles the antenna reduces nighttime fadeout almost entirely. Also the SELECT-A-TENNA usually helps in rejecting an overriding station of similar frequency.

The SELECT-A-TENNA works by focusing radio waves like a magnifying lens focuses light. When positioned correctly, the SELECT-A-TENNA focuses the signal from a distant broadcaster onto the built-in antenna of your radio.

AM antennas (the SELECT-A-TENNA included) are directional. They work best when aimed toward the station you are trying to receive. The position of your radio and that of the SELECT-A-TENNA next to it are very important for maximum performance. Maximum signal strength is obtained when the back face of the SELECT-A-TENNA is parallel to a line drawn toward the desired station (See drawing with arrow). Keep this in mind as you follow the operating instructions below.

### **INSTRUCTIONS**

1. Tune your radio to any very weak AM station. It is important that the station be weak so you can clearly detect the improvement in reception. The SELECT-A-TENNA has no noticeable effect on strong stations.
2. Place the SELECT-A-TENNA next to the radio as shown in Drawing "A" (see over). Adjust the tuning knob on the SELECT-A-TENNA and listen for changes in reception. Reception should improve immediately. If not, try another position as shown in drawings "B", "C", or "D" (over) and continue with step 3.
3. Move the SELECT-A-TENNA to various positions near the radio. You are looking for the "sweet spot" where improvement is greatest. Once found, this will be the set-up that works for ALL STATIONS with your radio. To fine-tune for stations in different geographic locations, rotate the radio and SELECT-A-TENNA as a unit until you find the position that gives you the best results.
4. Finally, re-tune both the radio and the SELECT-A-TENNA (using their knobs) for best performance.

## OPERATION HINTS

With most radios the best position for the SELECT-A-TENNA will be similar to one of the illustrations below. The best location for the SELECT-A-TENNA depends somewhat on the location of the radio's built-in antenna. Boom Boxes and other large radios usually benefit from using the configuration shown in drawing "C". A few radios have their antennas on the left side of the radio. On these radios try placing the back of the SELECT-A-TENNA about one-half inch away from the left-hand side of the radio as shown in drawing "D". The Baygen Freeplay radio has an antenna that is mounted at right angles to the front of the radio. The Baygen is the only radio where the back of the Select-A-Tenna can go directly against the back of the Baygen.

A tiny minority of radios have shielding which makes the SELECT-A-TENNA ineffective with those radios. Try the SELECT-A-TENNA with a different radio (a small portable is best) to see if this is the case with your radio.

Further hint: Chances are you have a specific station in mind already and will feel satisfied when you've improved your reception for that one station. But don't pass up the empty spots on the radio dial. Test them by tuning the SELECT-A-TENNA and the radio together across the dial. You may be pleasantly surprised to hear distant radio stations where you thought there was no signal at all.

Point the Select-A-Tenna in the general direction of the station you want to receive.

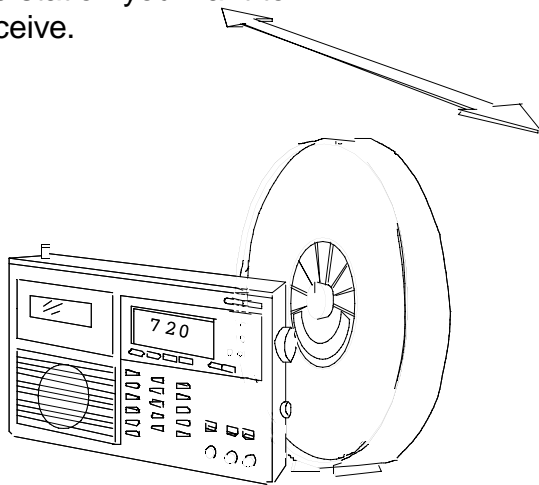

## ABOUT RADIO NOISE

Radio noise is an annoying buzz or whistle which is sometimes heard along with the station you are trying to receive. This may be caused by many things: home computers, dimmer switches, automatic night lights, fluorescent lights, televisions, and electric motors (drills, blenders, even aquarium pumps). Either turn off the offending device or rotate your radio and the SELECT-A-TENNA with respect to the device to nullify the buzz or whistle. If you are experiencing a buzz across the entire AM band, there may be too much interference for the antenna to be effective. Please read the section in our catalog about radio noise.

