

Long Range WiFi Bridge System Connection Diagram

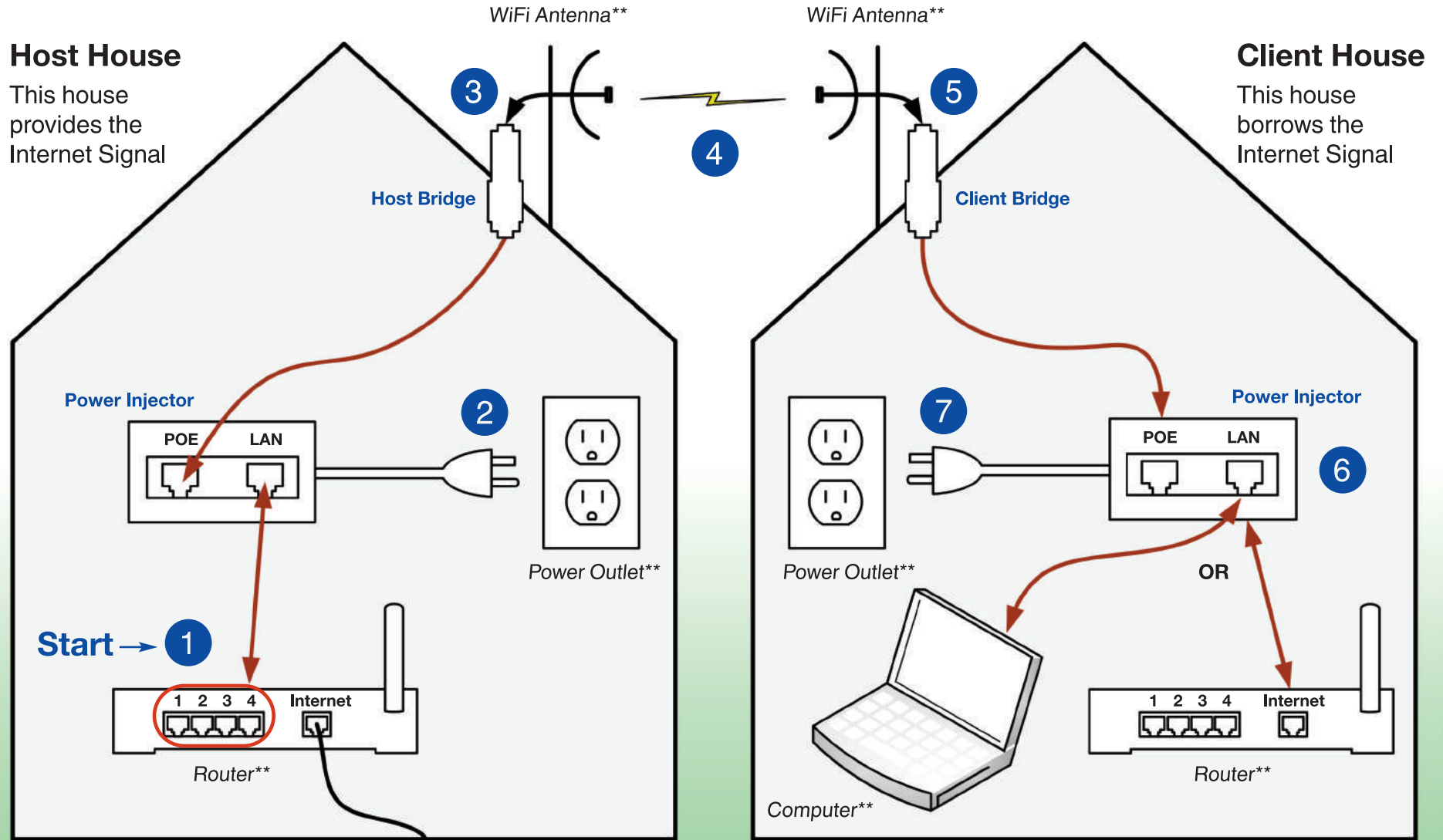

Host House
This house provides the Internet Signal

Client House
This house borrows the Internet Signal

**** Items not included with this system.**
See other side for list of items included with this system.
See other side for important Safety Warnings.

— = Ethernet Cable
⚡ = WiFi Connection

Long Range WiFi Bridge System

List of Contents

NOTE: The Long Range WiFi Bridge System does not require programming by the user. Please DO NOT RESET the system for any reason. We recommend contacting C. Crane's Technical Support if this system is not working properly.

Items for Host:

- 1 Host Bridge
- 1 50-foot Ethernet Cable
- 1 5-foot Ethernet Cable
- 1 POE Power Adapter
- 1 Pack of Coax Seal
- 1 Pack Silicone Grease

Items for Client:

- 1 Client Bridge
- 1 50-foot Ethernet Cable
- 1 5-foot Ethernet Cable
- 1 POE Power Adapter
- 1 Pack of Coax Seal
- 1 Pack Silicone Grease

The equipment in this kit has been pre-configured by C. Crane to work right out of the box. Please follow the **Connection Diagram** on the reverse side and the **Long Range WiFi Bridge System Setup Guide** for proper installation.



Before Use



**Please read these IMPORTANT SAFETY WARNINGS before use.
It is important to read and understand all instructions.**

Lightning

You may need to ground your antenna if you live in an area prone to lightning.

Power Lines

Never mount an antenna near power lines. If a power line falls and comes into contact with your antenna, DO NOT TRY TO REMOVE IT. Call your local power company.

Wind

Installing an antenna on windy days can be dangerous. Slight winds can create strong forces against the antenna equipment.

If you have any doubts about your ability to install your antenna safely, please hire a licensed, bonded professional to do the work. C. Crane is not responsible or liable for damage or injury resulting from antenna installations.